

# ARCHIVED REPORT

For data and forecasts on current programs please visit  
[www.forecastinternational.com](http://www.forecastinternational.com) or call +1 203.426.0800

## TLQ-32 (ARM Decoy) - Archived 7/2006

### Outlook

- In production, with ongoing logistics support
- Protects TPS-70/75(V) battlefield radars
- Other radar applications questionable

10 Year Unit Production Forecast  
2005 - 2014

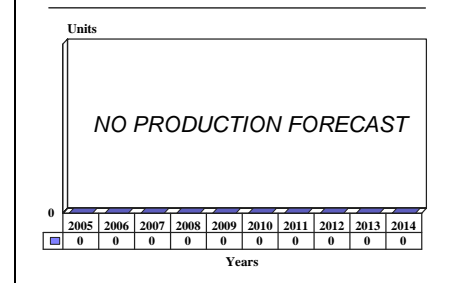

### Orientation

**Description.** This is a ground-based system that produces a decoy signal to protect battlefield radar from anti-radiation missiles.

#### Sponsor

U.S. Air Force  
 Electronic Systems Center  
 ESC/PAM  
 Joint Program Office  
 Hanscom AFB, Massachusetts (MA) 01731-5000  
 USA  
 Tel: +1 (617) 377-5191  
 Web site: <http://www.hanscom.af.mil>

**Status.** In production, ongoing logistics support.

**Total Produced.** Through 2004, 43 systems have been produced.

**Application.** Used with the TPS-75(V) tactical air defense radar. Other applications could develop.

**Price Range.** Estimated production unit cost is \$800,000 to \$1.2 million, depending on ancillary requirements.

### Contractors

ITT Gilfillan, <http://www.itgil.com>, 7821 Orion Ave, Van Nuys, CA 91409 United States, Tel: +1 (818) 988-2600, Fax: +1 (818) 901-2435, Prime

### Technical Data

	<u>Metric</u>	<u>U.S.</u>
<b>Dimensions</b>		
Emitter unit	1.8 x 9 x 9 m	7 x 3 x 3 ft
Unit weight	50.8 kg	112 lb
<b>Characteristics</b>		
Frequency	2.9 to 3.1 GHz	
Power	680 W (nominal)	
Coverage	360°	
Setup/teardown	< 15 min	

Lift/carry	2 persons per module
Modules per system	3 + power source
<b>Characteristics (continued)</b>	
MTBF	> 1,100 hr demonstrated
MTTR	< 15 min
Power requirement	2.5 kW (GFE generator)
Units	Central control unit (CCU) Emitters (3) Redundant fiber-optic links

**Design Features.** Anti-radiation missiles (ARMs) usually home in on the sidelobes of a radar, since the usual antenna rotation rate of 10 rpm eliminates the main beam as an ARM targeting source. Radars can be upgraded with an ultra-low sidelobe antenna to reduce the level of energy radiated, making a decoy system possible.

Decoy systems attempt to either saturate the ARM seeker or mask the radar's sidelobes. Modern seeker sensors are almost impossible to saturate without unacceptably large decoy transmitters. Masking is the most viable, cost-effective option. Any decoy signal must faithfully duplicate the emission signature that the ARM is programmed to seek – the signal pattern it would see as the antenna rotates.

The TLQ-32(V) consists of a transmitter assembly, modulator assembly, control/monitor, and antenna. The units are integrated on a pallet, with the antenna extending above the center (transmitter) module. They are interconnected by fiber-optic cable to a control unit in the radar operations shelter and protected with Kevlar. The system was designed for either fully automatic or manual operation. There is an extensive built-in test capability for ease of maintenance, and the modularity makes rapid setup and teardown possible.

The radar operator controls the system with the Central Control Unit (CCU) in the TPS-75(V) operations shelter. Three independent emitters each include a synthesizer, modulator, RF amplifiers, and control circuits; all are shock-mounted inside polypropylene transit cases that snap together to configure the emitter. The antenna at the site is installed with a quick-disconnect clamp, while a redundant fiber-optic link consists of two fibers in a loop with the data flow going in opposite directions. Optical transmitters are located at the CCU and each emitter.

The TLQ-32(V) was designed to produce a decoying signal that emulates the sidelobe radiation pattern of the TPS-75(V) tactical radar. The CCU accepts radar triggers and frequency code information, which are converted into command messages and sent via fiber-optic link to the emitters. The command messages consist of a timing signal and a frequency code, and an

indicator for selecting which emitter to radiate. They are sent to the emitters, and the emissions are set up. This involves tuning the emitter to the approximate frequency of the next radar pulse and initiating the pulse timing. The decoy pulse is internally modulated to a 13-bit Barker code.

Three transmit units are located some distance from the radar, and either mask the sidelobe signals so that an attacking ARM's seeker cannot locate the radar, or deceive incoming anti-radiation missiles into exploding harmlessly away from the radar's antenna without destroying the decoy emitter.

The design facilitates the rapid replacement of faulty modules. The emitters are form-fit-function identical, and a line-replaceable unit or complete case can be replaced without the need for adjustment or alignment. It has an extensive built-in test capability.

Although the initial systems are limited to use with the TPS-75(V) because the modulator is hardwired to simulate the associated radar's antenna pattern, the system can be changed to emulate other systems. The hardwiring could be changed, or a software adaptation of the output signal could be developed. This would make it easier to adapt the TLQ-32(V) ARM Decoy to other radars.

**Operational Characteristics.** Anti-radiation missiles use aircraft sensors to locate radar sites that pose a threat to an attack. After launch, the missile's onboard sensors home in on the radar by sensing the characteristic pattern of the antenna sidelobes. The missile then explodes close to the antenna in an attempt to put the radar out of commission.

The ARM Decoy's function is to mislead the missile seeker enough to make it impact or detonate harmlessly away from the main radar antenna. One anti-missile technique involves shutting off the radar transmitter, depriving the ARM of a signal to home in on. However, this puts the radar temporarily out of service during an attack - the goal of the attacker anyhow.

The TLQ-32(V) emitters are located away from the radar to be protected. With the three units set up in a configuration specifically tailored to provide incoming

anti-radiation missiles with a more attractive target than the original radar antenna, the system masks the true sidelobes by specifically emulating the sidelobe pattern of the radar, the pattern on which the missile homes. Designers call the area in which the missile impacts the "ARM pit." Distances and deployment schemes are

classified. Minor adjustments in the field can match the decoy to its particular radar.

Because the TPS-75(V) is deployed to contingency operations worldwide, the TLQ-32(V) is configured for rapid deployment, operation in environmental extremes, and all-terrain installation.

## Variants/Upgrades

The system can be expected to be adapted to a variety of radar. Likely candidates are frontline radar operating in the general frequency band of the TPS-75(V), and include the MPQ-53(V) Patriot and TPQ-37(V) FIREFINDER. The potential exists for moving to other

frequency bands, and the MPQ-64(V) FAADS ground-based radar is a prime candidate. This would necessitate an architecture change, but the technology is applicable.

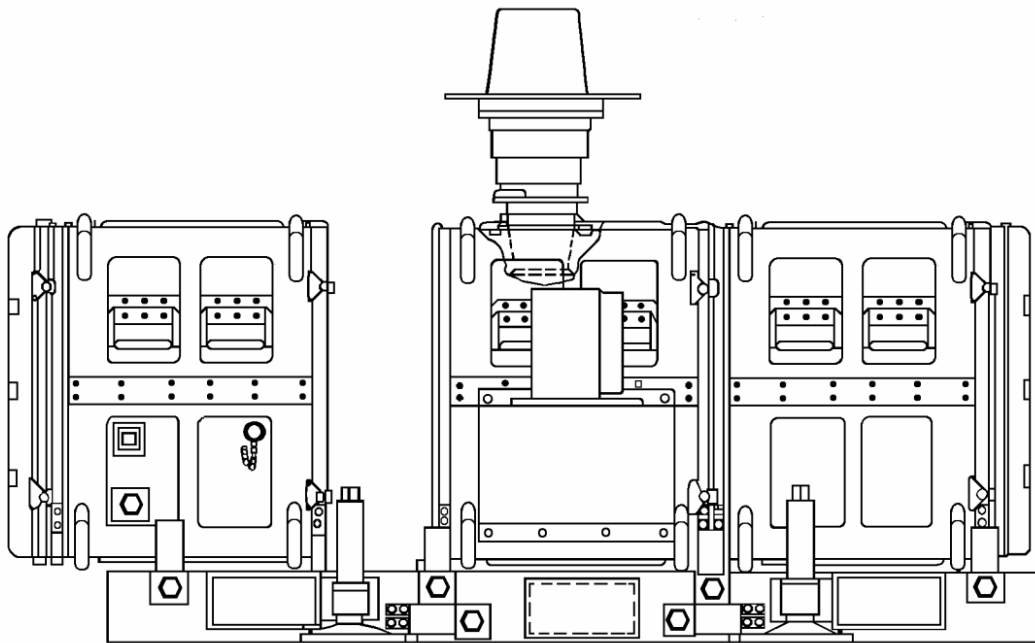

TLQ-32 ARM Decoy

Source: Forecast International



Protection for TPS-75(V)

Source: Northrop Grumman

## Program Review

In November 1989, the Air Force solicited development of an anti-radiation missile decoy system to protect battlefield radar assets. The specific system to receive the decoy units was the TPS-75(V) 3-D search radar for the Tactical Air Control System.

ITT Gilfillan was awarded a pre-production development and delivery contract in July 1990. After a series of funding adjustments to compensate for failure to originally allocate enough funds for the program, a production contract was awarded in March 1993. Fourteen systems were to be produced and two preproduction systems refurbished by 1994.

In November 1993, the Air Force published a notice of intent to solicit production of an additional 19 TLQ-32 systems. Deliveries would be made over 18 months.

In August 1994, the Air Force published a notice of intent to solicit an additional production of two TLQ-32(V)s over 18 months.

In August 1995, the Air Force published a source solicitation notice for the production of one TLQ-32(V) anti-radiation missile (ARM) Decoy system. The system was to be delivered in 18 months.

A June 1999 issue of *Commerce Business Daily* published a notice of a pending contract for one year of depot-level support services. The award would include four annual renewal options.

## Funding

---

Specific funding sources have not yet been identified.

## Recent Contracts

---

No recent contracts over \$5 million recorded.

## Timetable

---

<u>Month</u>	<u>Year</u>	<u>Major Development</u>
	1970s	ARM capability demonstrated in combat in the Middle East (Arab-Israeli and Iran-Iraq conflicts)
	FY86	Initial concept development
Nov	1989	Solicitation released
Apr	1990	Solicitation completed
Jul	1990	Contract for pre-production units
Feb	1992	First article testing at China Lake Test Center
Mar	1993	Production approval/contract (14 systems)
Nov	1993	Solicitation announcement for additional 19 systems
Aug	1994	Solicitation announcement for additional two systems
	1994	Delivery of first production lot completed
May	1995	Estimated completion of Lot 1 deliveries
	1996	Deliveries continue
	2004	Production ends

## Worldwide Distribution

---

This is a U.S.-only program for the TPS-75(V) thus far. The extensive use of the TPS-43/70/75 radar family around the world created a market opportunity that apparently has not brought orders.

## Forecast Rationale

The TLQ-32(V) program originally had a problem with funding allocated to U.S. Air National Guard and Air Force Reserve accounts, even though most tactical air control units were in the Guard and Reserve. Production was initially delayed, but ARM Decoy efforts have since become a high priority for the Air Force.

The major drawback of the system is that its hardwired modulator limits protection to a single radar. Engineers would have to develop either new hardwiring to adapt it to other radar, or a software upgrade to allow the units to be programmed for other radars. ARMs are more sophisticated, and newer ones can effectively home in on a radar even if the transmitter is shut down, so deception may be the best protective measure.

The application of the ARM Decoy concept to other critical frontline radars is desirable, although funding is a problem. Future sensor designs may begin to incorporate low observability instead of ARM Decoys

as part of the development scheme. However, there is a newly growing focus on developing a next-generation family of battlefield radars, such as G/ATOR, that use active arrays and can be low-observable enough to reduce the HARM threat to roughly the same level as with decoys.

A one-to-one procurement was not necessary, since not all radars are at risk at the same time. Budget constraints made it impossible to acquire an ARM Decoy for every radar in the inventory. However, enough systems are available to protect the number of radars expected to face a high-speed radiation missile threat at one time.

European competition could cut into the international market if manufacturers introduce systems specifically tailored for indigenous radars.

The production of spare modules, repair parts, and backup emitters will support units in the field.

## Ten-Year Outlook

---

No further production beyond ongoing support is expected.

\* \* \*