

ARCHIVED REPORT

For data and forecasts on current programs please visit

www.forecastinternational.com or call +1 203.426.0800

Mark F3 155 mm Self-Propelled Howitzer - Archived 4/97

Outlook

- The Mark F3 is out of production
- A total of 621 Mark F3 systems was manufactured
- Some additional modernization and retrofit potential exists for the remaining systems

10 Year Unit Production Forecast
1997 - 2006



Orientation

Description. A tracked 155 millimeter self-propelled artillery system

Sponsor. This weapon was originally sponsored by the French Ministry of Defense, Délégation Générale pour l'Armement, Direction des Armements Terrestres through the Direction Centrale du Matériel de l'Armée de Terre. Later developmental support was provided by Creusot-Loire Industrie.

Contractors. This weapon was manufactured by Creusot-Loire Industrie; Paris, France. In 1993, Creusot-Loire Industrie became a component of the Eurovecteur division of Giat Industries. Major subcontractors included Detroit Diesel Corporation, Giat Industries, Moteurs Baudouin and SOFAM.

Licensees. The Government of Argentina manufactured the Mark F3 under license; this agreement lapsed many years ago.

Status. The manufacture of the Mark F3 system has terminated. The system remains in service in France and a number of other nations.

Total Produced. A total of 621 Mark F3 systems was manufactured.

Application. General artillery support for the field army at the battalion or division level.

Price Range. In equivalent 1991 United States dollars, this artillery system had a unit price of \$1.31 million.

Technical Data

Crew. Two: driver and commander; eight men are required to operate the weapon; the remaining crew are in the accompanying support vehicle.

Muzzle Brake. Double-baffle

Recoil System. Hydropneumatic

Breach Mechanism. Interrupted screw, stepped thread

Ammunition. Mark 56, M107 (High Explosive), High Explosive Rocket Assisted Projectile, Illumination, Smoke, and chemical.

Armor. The Mark F3 is fabricated from all welded steel alloy armor with a maximum thickness of two centimeters (0.78 inch) on the sides and portions of the floor.

Dimensions. The following dimensional data are for the last production standard.

	<u>SI units</u>	<u>US units</u>
Length overall	6.22 meters	20.41 feet
Width	2.71 meters	8.89 feet
Height	2.09 meters	6.86 feet
Combat weight	17.4 tonnes	19.18 tons
Fuel capacity	450 liters	119.68 gallons
Ordnance caliber	155 millimeters	6.10 inches
Ordnance length	33 calibers/5.12 meters	33 calibers/16.79 feet

Performance. The maximum vehicle speed and range is on a metallated road; the vehicle range and speed data are with the original engine; with a diesel powerplant, the range is 450 kilometers (279.5 statute miles) and top speed is 64 kilometers per hour (29.7 miles per hour). The maximum ordnance range is with the High Explosive projectile. The traverse figure is at a 0 to 50 degree elevation.

Maximum speed	60 kilometers per hour	37.3 miles per hour
Maximum range	300 kilometers	186.31 statute miles
Step	60 centimeters	1.97 feet
Trench	1.5 meters	4.92 feet
Slope	28%	28%
Gradient	40%	40%
Fording	1.0 meters	3.28 feet
Elevation	+67°	+67°
Depression	0°	0°
Traverse	20° left 30° right	20° left 30° right
Maximum ordnance range	20.047 kilometers	27,658 yards
Maximum rate of fire	4 rounds per minute	4 rounds per minute
Sustained rate of fire	1 round per minute	1 round per minute

Engine. Originally, this vehicle was equipped with the SOFAM model 8Gxb spark ignition engine rated at 186.5 kilowatts (250 horsepower) at 53.34 revolutions per second (3,200 revolutions per minute). The power-to-weight ratio with this engine is 10.72 kilowatts per tonne (13.03 horsepower per ton). The last production standard engine was the Detroit Diesel Corporation 6V-53T supercharged, six-cylinder, liquid-cooled diesel rated at 208.88 kilowatts (280 horsepower) at 46.67 revolutions per second (2,800 revolutions per minute). The power-to-weight ratio with this engine is 12.00 kilowatts per tonne (14.60 horsepower per ton). An optional engine was the Moteurs Baudouin 6 F 11 SRY six-cylinder diesel rated at 208.88 kilowatts (280 horsepower); this engine is mainly offered as part of a retrofit package. A 24 volt electrical system with four

12 volt 190 ampere hour batteries is the standard electric fit for this vehicle.

Gearbox. An unspecified manual unit with five forward and one reverse gear ratios; an automatic gearbox with three forward and one reverse gear ratios was optional.

Suspension and Running Gear. The Mark F3 uses a torsion bar type suspension with five single tired road wheels and three track return rollers on each side. The last road wheel acts as the idler and the first and last road wheel stations are provided with hydraulic shock dampers.

Fire Control. The fire-control equipment includes an APX L877G direction finder and an APX M321 sighting telescope.

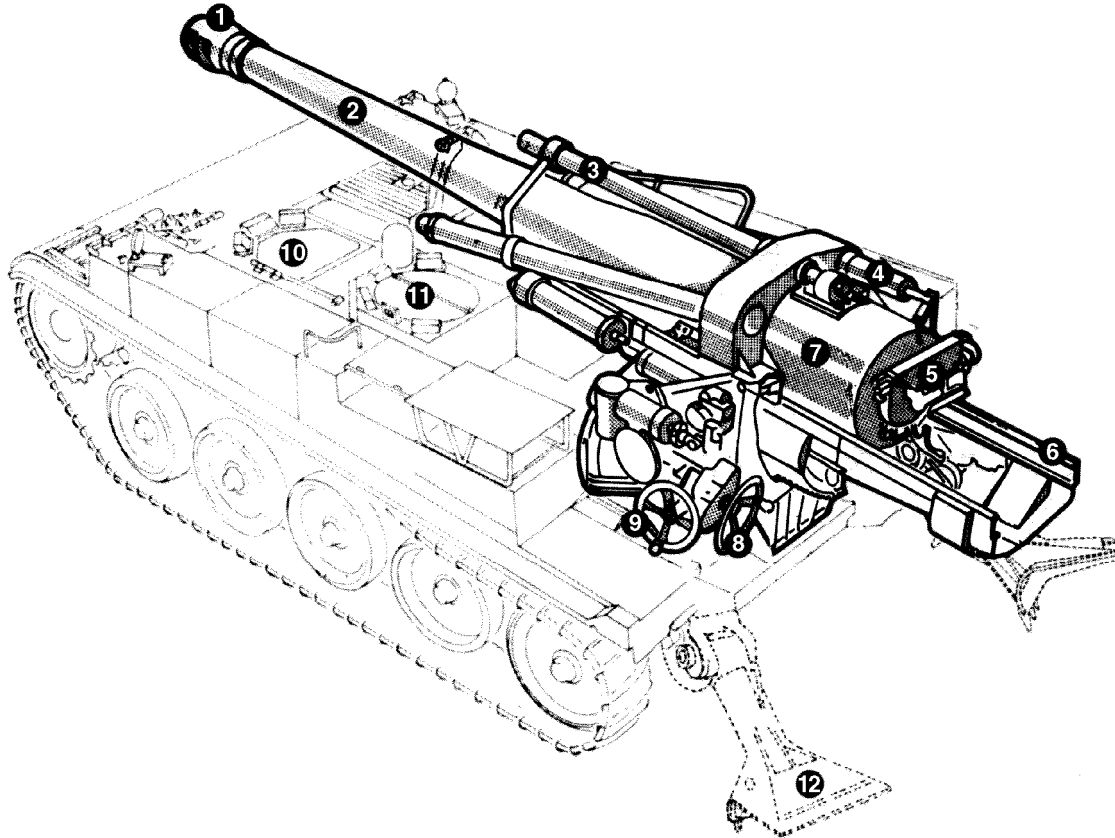

- | | | |
|--------------------------|-----------------------------|-------------------------|
| 1. Muzzle brake | 2. Barrel | 3. Recuperators |
| 4. Breech equilibrator | 5. Breech block flap | 6. Slide |
| 7. Breech sleeve | 8. Elevating handwheel | 9. Traversing handwheel |
| 10. Driver's compartment | 11. Commander's compartment | 12. Anchoring spade |

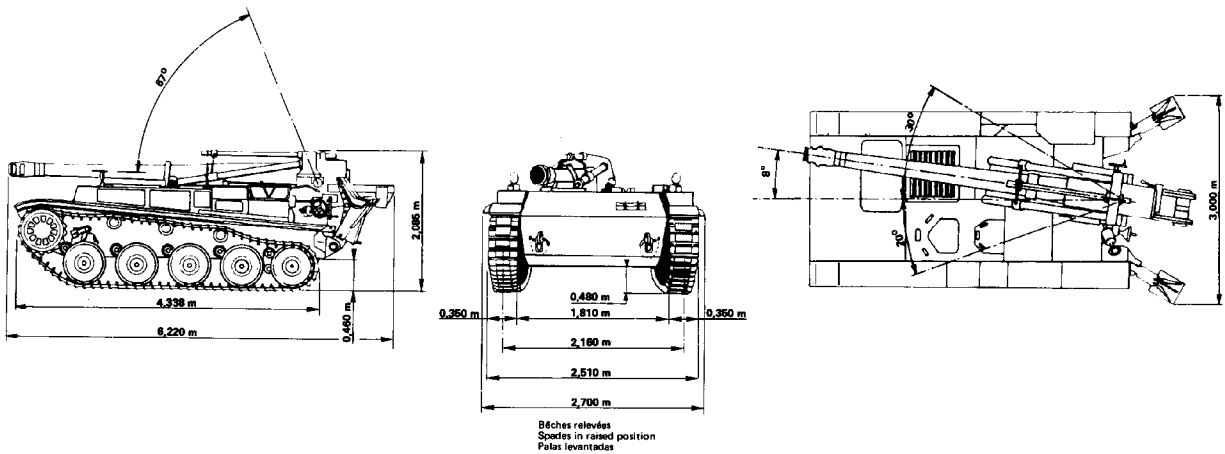

Mark F3 155 mm Self-Propelled Howitzer

Source: Forecast International

* * *